



# Actros B-Double Prime Mover.

Mercedes-Benz  
Trucks you can trust



# The Mercedes-Benz B-Double Prime Mover Range.

The Mercedes-Benz B-Double Prime Mover range impresses not only with a comfortable driver workplace, but also with precisely coordinated, job-matched vehicle configurations, fuel saving, efficient technology and attractive service offers which can increase the overall cost effectiveness further still.

**Reliability.** Operators who earn their money in road-bound goods transport need absolute reliability. In other words: trucks they can count on. With the Actros we are able to offer you a vehicle incorporating the rich fund of experience and expertise acquired over more than 100 years of German engineering. Equipped with leading Mercedes-Benz vehicle technology and components tested under the toughest conditions. This applies to engines, gearshifts, transmissions and drive axles as well as frames, chassis, suspension and cabs. Everything is perfectly coordinated, in order to meet all requirements reliably, even in extreme conditions.

**Efficiency.** Mercedes-Benz trucks stand for particularly high economic efficiency worldwide. The Actros also meets the highest standards of efficiency, based first and foremost on its particularly low fuel consumption. Low wear and a higher resale value are additional merits contributing to its high overall economic efficiency. To this end, numerous innovative technical measures were implemented in the course of developing the Actros. These result in engines with higher performance and lower fuel consumption, a powertrain which enables a particularly economical driving style, and an aerodynamic design honed down to the finest details in the interests of fuel efficiency.

**Comfort.** Anyone who spends a lot of time on the road needs space of their own. And space for the essentials needed on long journeys. This is why the cabs of the Actros offer particularly spacious interiors – with vast amounts of stowage space and plenty of freedom of movement. In short, working, living and sleeping comfort which is geared to the work of long-distance drivers and meets their high expectations, too.

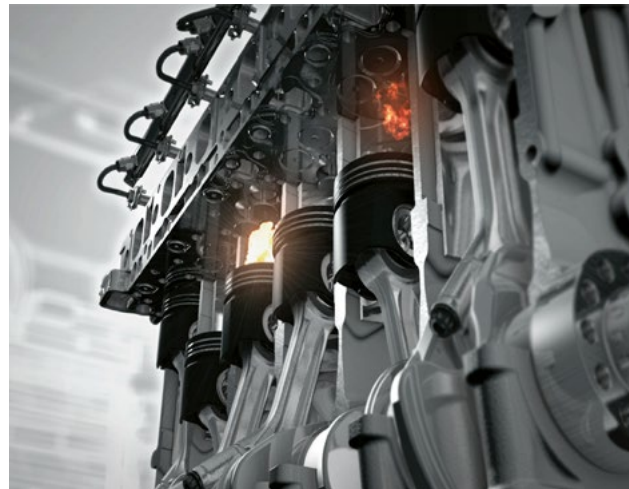

**ClassicSpace L-cab, 2.30 m, tunnel 170 mm.** The comfortable cab has been designed in accordance with the latest ergonomic and safety principles and offers the driver a high level of comfort and a pleasant ambience.

**StreamSpace L-cab, 2.50 m, level floor.** The cab has been specially optimised for low fuel consumption. Thanks to its width and the headroom of 1.97 m between the seats, it offers plenty of space and a high level of comfort. The cab has been designed in accordance with the latest ergonomic and safety principles; the level floor facilitates through-cab access to the co-driver's side.



**Consumption.** The economical engines are available in two displacement classes from 12.8 l (Euro VI only) to 15.6 l (Euro V or Euro VI) and a total of 3 power output ratings of 390 kW (530 hp), 425 kW (580 hp) and 460 kW (625 hp). In conjunction with the precisely tuned powertrain configurations and the sophisticated aerodynamics, these engines achieve fuel savings of up to 7%\* compared with the predecessor model.

\*The declared fuel consumption figures are determined by testing under standardised laboratory conditions to comply with ADR 81/02. Real world fuel consumption is influenced by many additional factors such as individual driving style, load, traffic and vehicle condition. The declared fuel consumption figure should only be used for the purpose of comparison amongst vehicles.

Description	Vehicle 1	Vehicle 2	Vehicle 3	Vehicle 4
Segment	B-Double	B-Double	B-Double	B-Double
Range	Actros	Actros	Actros	Actros
Model	2653	2653	2658	2663
Wheelbase	3250	3250	3250	3250
Drivetrain	6x4	6x4	6x4	6x4
Engine	OM 471	OM 471	OM 473	OM 473
Engine power	530 hp	530 hp	580 hp	630 hp
Cab	L-Cab Classic Space 2.3 170 mm ET	L-Cab Stream Space 2.5 Level floor	L-Cab Stream Space 2.5 Level floor	L-Cab Stream Space 2.5 Level floor
Baumuster	96342422	96342422	96342422	96342422



# Equipment Highlights.

**Powertrain.** Mercedes PowerShift 3 provides fast shifting from forward to reverse and high-ratio reverse gears for easy manoeuvring. Moving off is noticeably more comfortable thanks to the crawl function.

**Rear axle guide.** The innovative rear axle guide also plays a decisive role in the excellent handling: compared with a conventional wishbone, the connection points of the two trailing arms are positioned further towards the outside. This results in the best possible transverse stability, little need for corrective steering and very good understeer/oversteer characteristics.

**Tank capacity.** Actros B-Double Prime Movers can be equipped with a tank capacity of up to 1100 litres. This makes for a long operating range and saves money by avoiding the need to retrofit add-on tanks. An optional 110 litre AdBlue tank is also available.

**Suspension components.** All the suspension elements in the Actros are precisely tuned to one another: from the seats to the cab mountings to the 8-bellow air suspension at the rear axles – the overall result is a high degree of suspension comfort for the workplace and a ride which helps protect both the vehicle and its cargo.

**Frame.** The frame of the Actros is uncompromisingly geared for use in long-distance transport. The 834 mm wide track and the rigid design ensure good roadholding and comfortable handling. Other advantages include the 50 mm matrix of pre-drilled holes throughout as well as a large range of wheelbases, frame overhangs and end cross members.

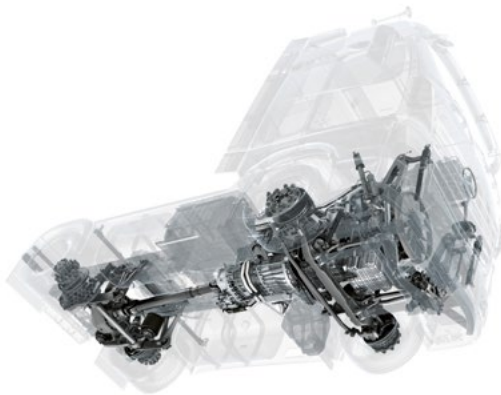

# Total Cost of Ownership.



**Agility.** A Mercedes-Benz Financial program, designed to provide exceptional flexibility and peace of mind. Best of all, Agility allows us to guarantee the future value of your vehicle, meaning when your truck comes to the end of the financial contract, you have the option to trade it in for a new vehicle, retain it, or return the vehicle\*.



**EcoTraining.** Mercedes-Benz EcoTraining teaches a way of driving that allows you to make even better use of the technical potential of your truck for even further fuel savings.



**Maintenance.** The information displayed in the cockpit provides you with advance warning about when your vehicle's next maintenance visit is due. This is determined on the basis of the continuous evaluation of data about the actual workload of the vehicle: for example, every single cold start, the degree of brake pad wear, the condition of the engine oil and all major assembly oils. In this way, maintenance can be planned anticipatively and can be combined with statutory inspections, for example. This avoids additional downtime.



**Mercedes-Benz service contracts.** From warranty extensions to maintenance packages to a comprehensive service package including wear items – the Mercedes-Benz graduated range of service contracts offers flexible repair and maintenance products which are geared to customers' requirements and which allow them to plan monthly costs and make optimal use of their fleet capacity.



**Ease of repair.** The introduction of the new Euro VI emissions standard brought with it considerable additional technical sophistication. Right back at the design stage, care was taken to ensure that all the components are not only particularly robust but can also be replaced or repaired particularly quickly and cost-effectively, resulting in lower costs and higher efficiency.



**Mercedes-Benz GenuineParts.** High-quality genuine parts at an affordable price will translate to value retention and overall economic benefits for you. The extensive range of parts, efficient logistics and quick availability across the country are further advantages.



\*Agility Finance is restricted to approved customers of Mercedes-Benz Financial Services Australia Pty Ltd ABN 73 074 134 517 and is subject to standard credit assessment and lending criteria. Please contact an authorised Mercedes-Benz dealer for further details and full terms and conditions (including vehicle eligibility). Guaranteed Future Value (GFV) is subject to Fair Wear and Tear return conditions and Excess Kilometre charges.

# Engines and Cabs.

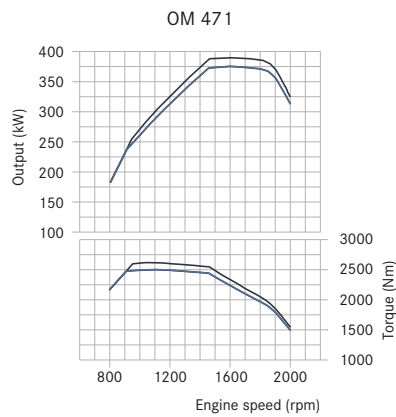

6-cylinder in-line, 12.8 l displacement

kW (hp)	Nm
at 1600 rpm	
375 (510)	2500
390 (530)	2600

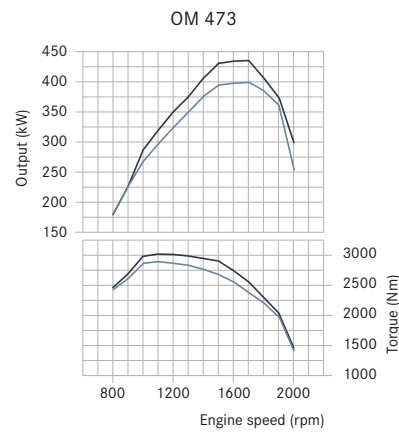

6-cylinder in-line, 15.6 l displacement

kW (hp)	Nm
at 1600 rpm	
425 (578)	2800
460 (625)	3000

ClassicSpace L-cab (2)  
(exterior width 2300 mm, engine tunnel)

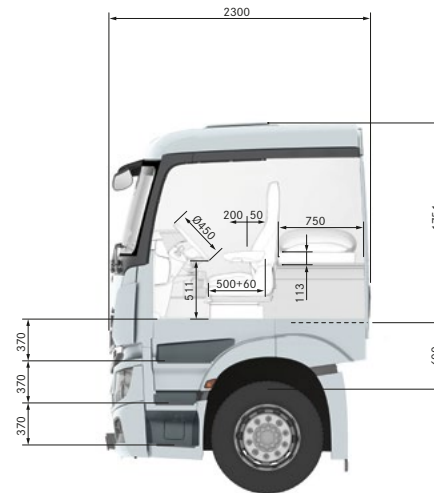

Engine tunnel: 170 mm  
Headroom on engine tunnel: 1460 mm  
Headroom in front of the seats: 1590 mm

StreamSpace L-cab (1)  
(exterior width 2500 mm)

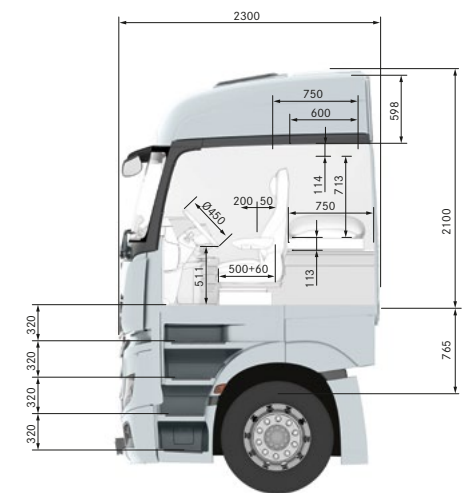

Headroom between the seats: 1970 mm  
Headroom in front of the seats: 1830 mm

# Advantages at a glance.

## Drive Train:

- Mercedes-Benz OM 471 12.8 litre and OM 473 15.6 litre engine options
- Fully automated 12 and 16 speed Mercedes-Benz PowerShift 3 transmission
- Fuel efficient single reduction axles
- Electronic Braking System incorporating ABS, Stability Control, Hill Hold and Traction Control

## Cab:

- Low roof sleeper cabs for day to day operation
- Flat floor sleeper cabs for regional or interstate operation
- Double zinc coated and cathodic dip priming for optimal corrosion protection
- Ergonomic cockpit designed with the drivers needs in mind
- Aerodynamically tested and designed for optimal efficiency on the road

## Value Add Services:

- 4 year, 800,000 km driveline warranty
- 2 year, unlimited km bumper to bumper warranty
- 5 year, 500,000 km free servicing included<sup>~</sup>
- Agility, Service Plans and Maintenance Contracts all available



<sup>~</sup>Free servicing offer subject to change. Contact your local authorised Dealer for further information.

Please note: changes may have been made to the products since this brochure went to press (October 2016). Contact your local authorised Mercedes-Benz Trucks Dealership for further information.  
[www.mercedes-benz.com.au/trucks](http://www.mercedes-benz.com.au/trucks)